

# Self-Learning Adaptive Ramp Metering

Kasra Rezaee, Ph.D.

*Post Doctoral Fellow*

Baher Abdulhai, Ph.D., P.Eng.

*Professor, Dept of Civil Engineering*

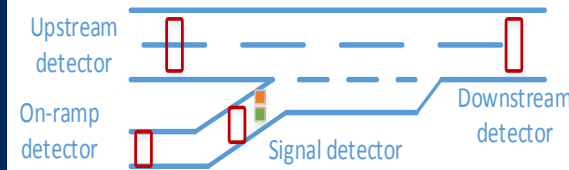

UNIVERSITY OF TORONTO  
FACULTY OF APPLIED SCIENCE & ENGINEERING  
Transportation Research Institute

# Freeway Traffic Control

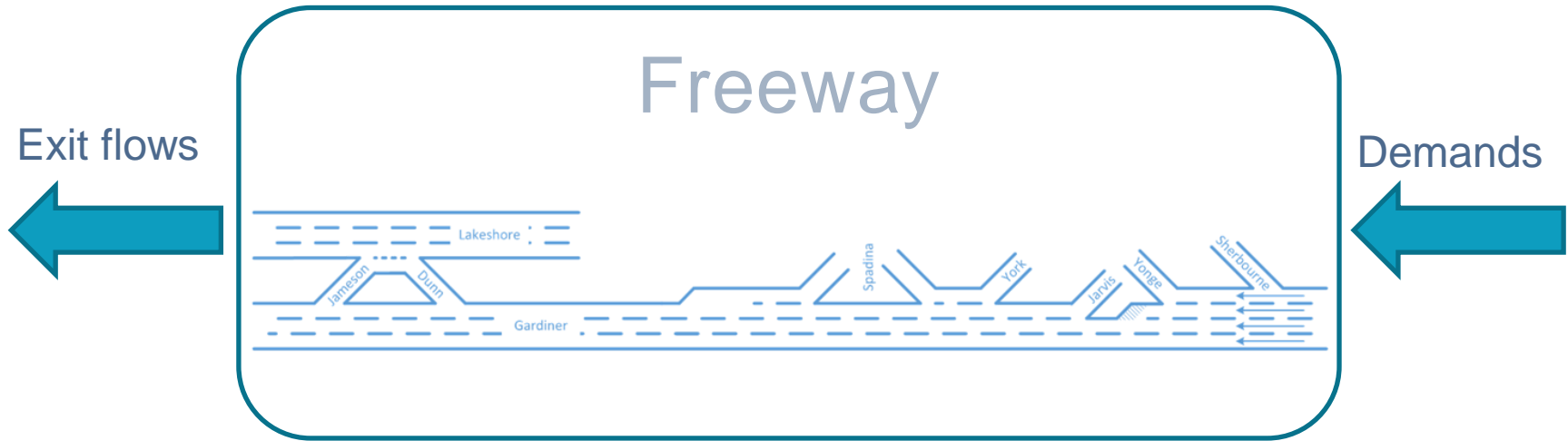

5% - 10% drop in freeway throughput

Optimal traffic condition

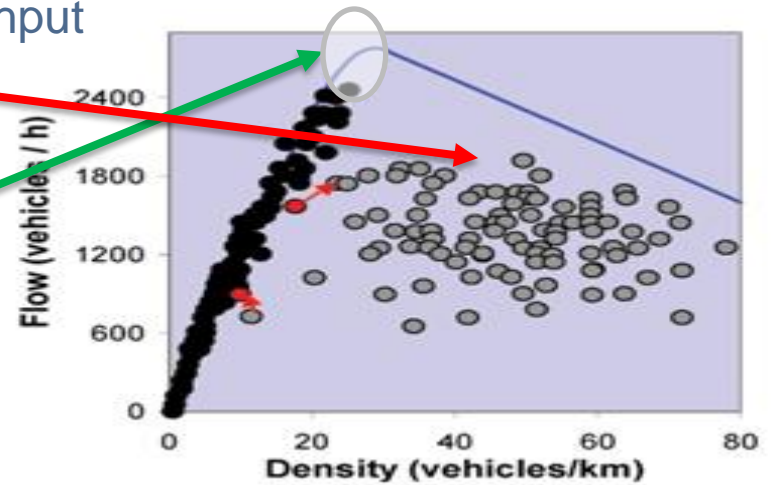

# Ramp Metering

- Ramp metering (RM) is the use of a traffic signal(s) employed on a ramp to control the pace at which vehicles enter a freeway

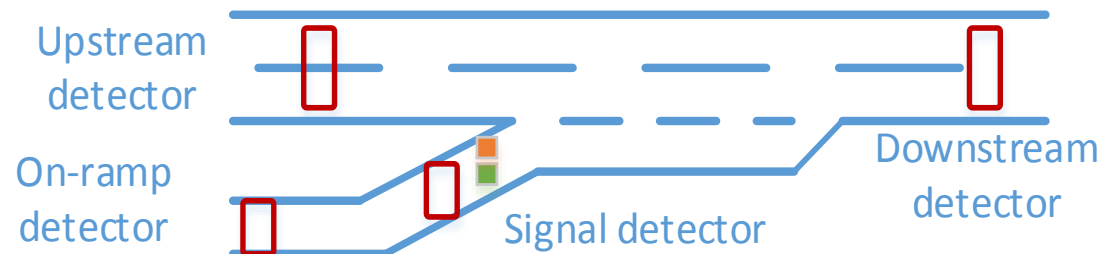

- Challenge
  - Avoid Counter productive excessive queueing at downstream on-ramps

# Reinforcement Learning

- Model-free control
- Agent goal:
  - Maximize expected reward
- Q-learning
  - Exploration vs. exploitation

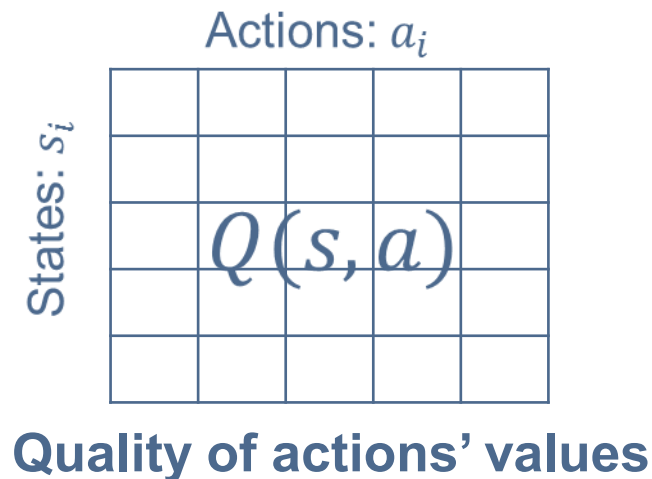
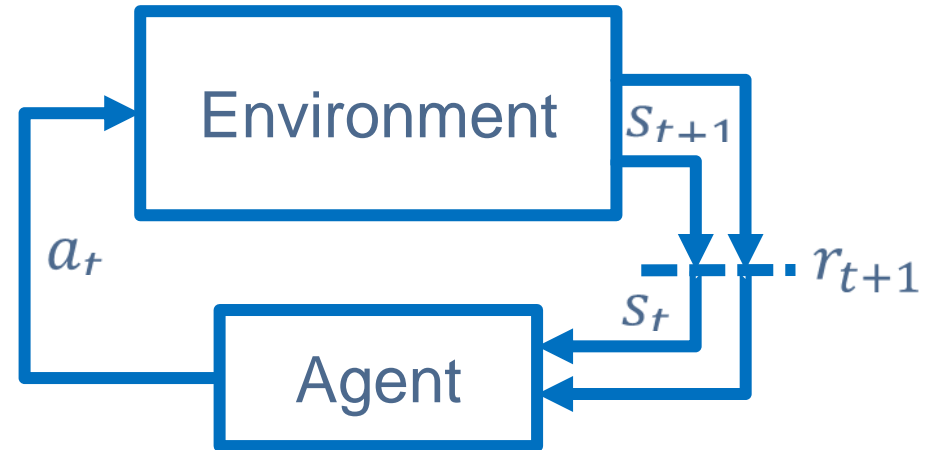

# Control of Multiple On-ramps

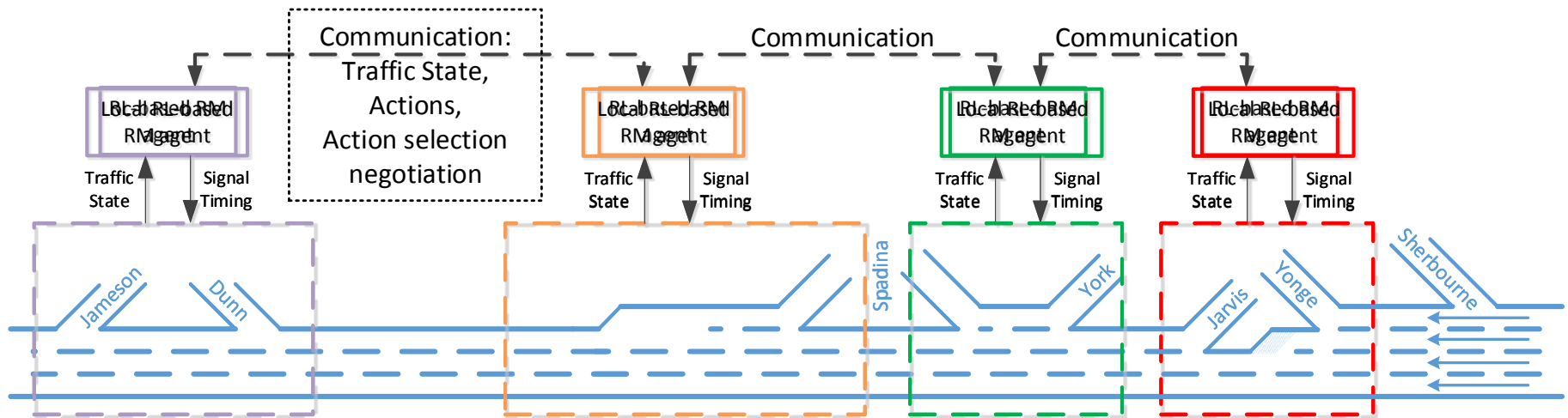

# 401 Eastbound Collector at Keele Street Freeway Ramp Metering Study



# Calibration of Paramics Network

- Driver Behaviour

- Freeway capacity
- Congestion propagation speed
- Freeway Breakdown

- Demand

- Realistic count
- Realistic congestion

Gardiner Expressway westbound from DVP to Humberbay

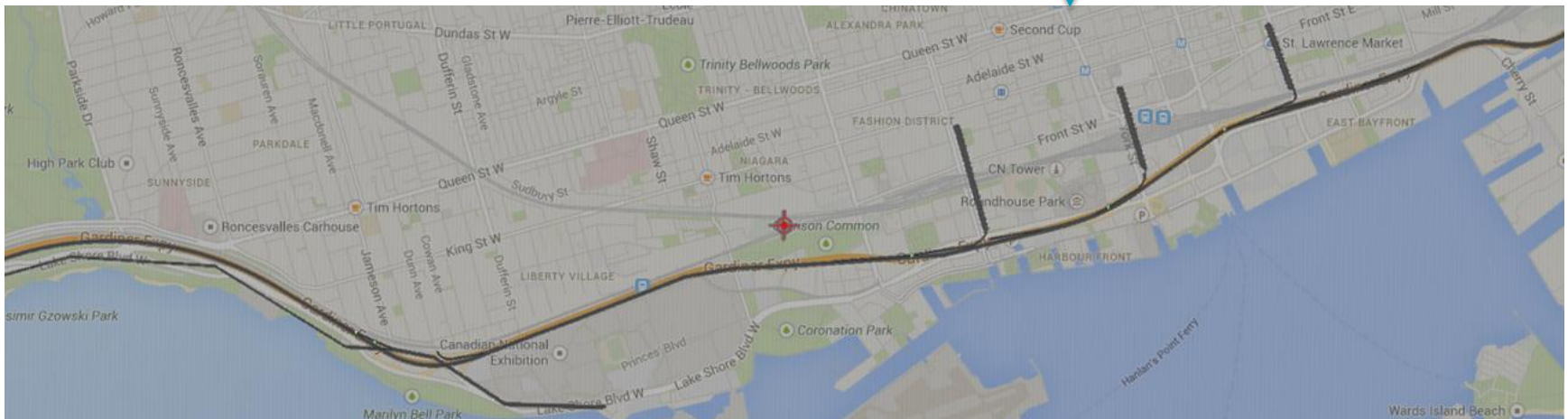

# Local vs. Coordinated

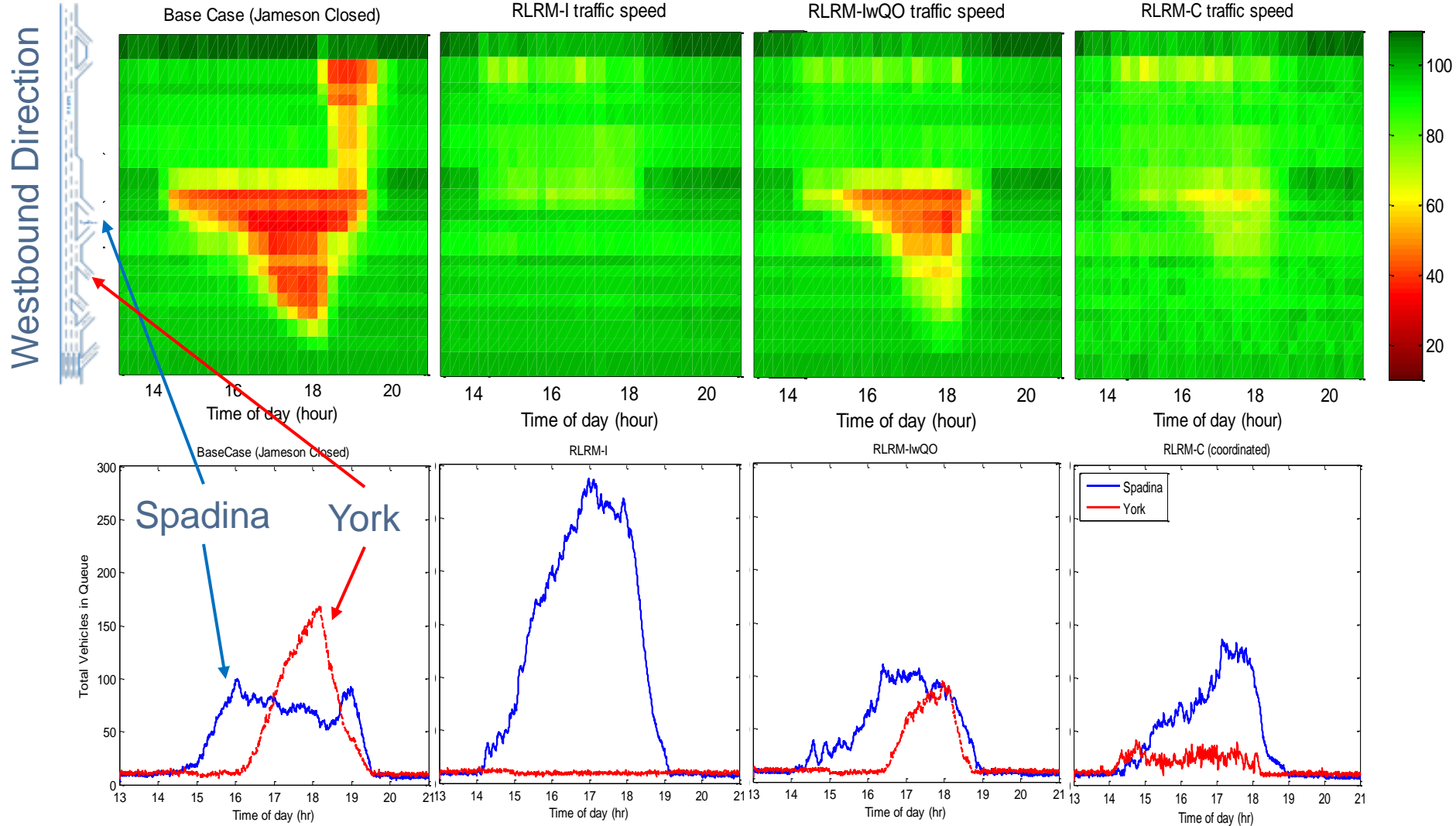



# Network Total Travel Time

Summary of network performance for different scenarios

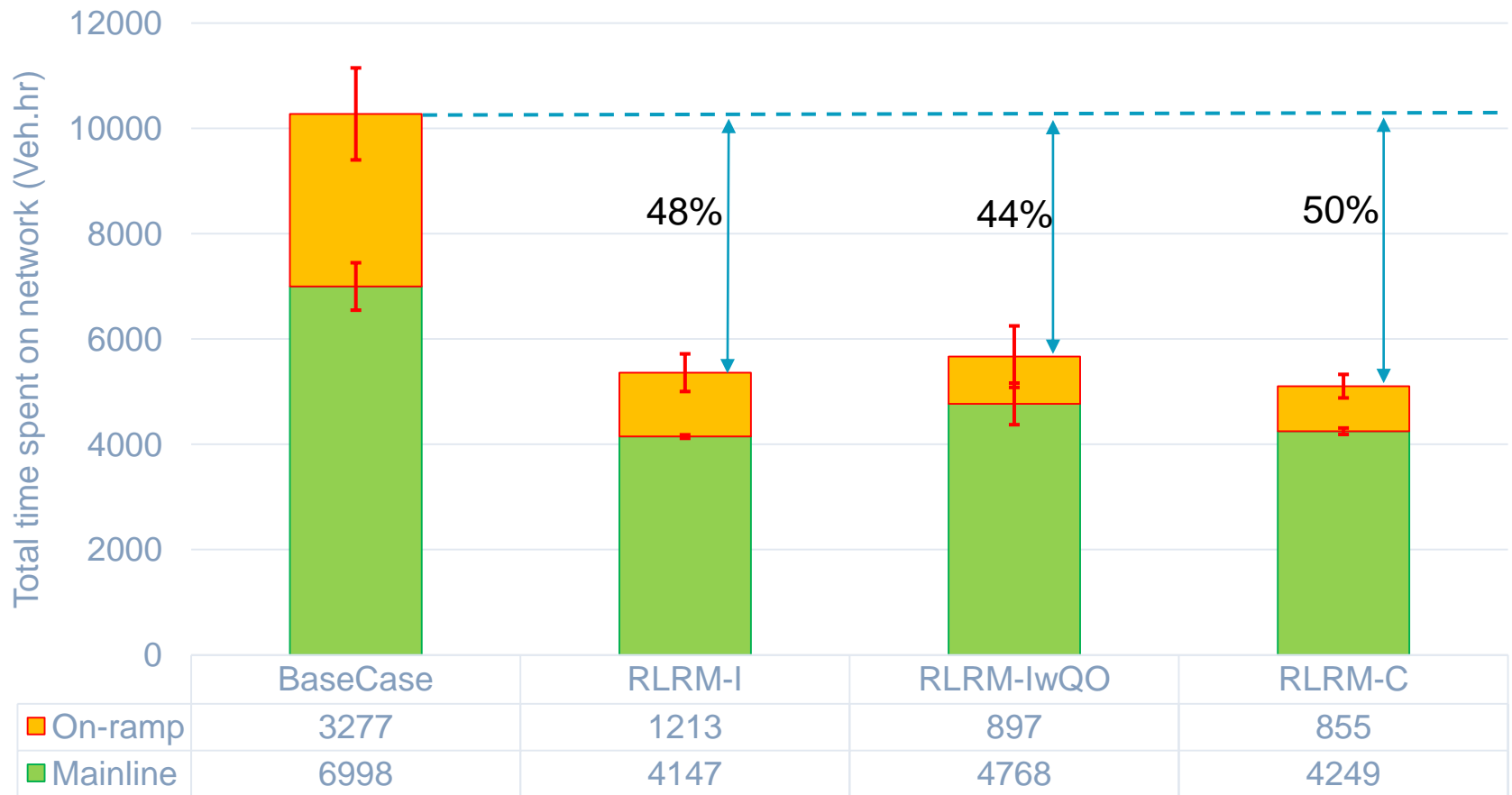

# Conclusion

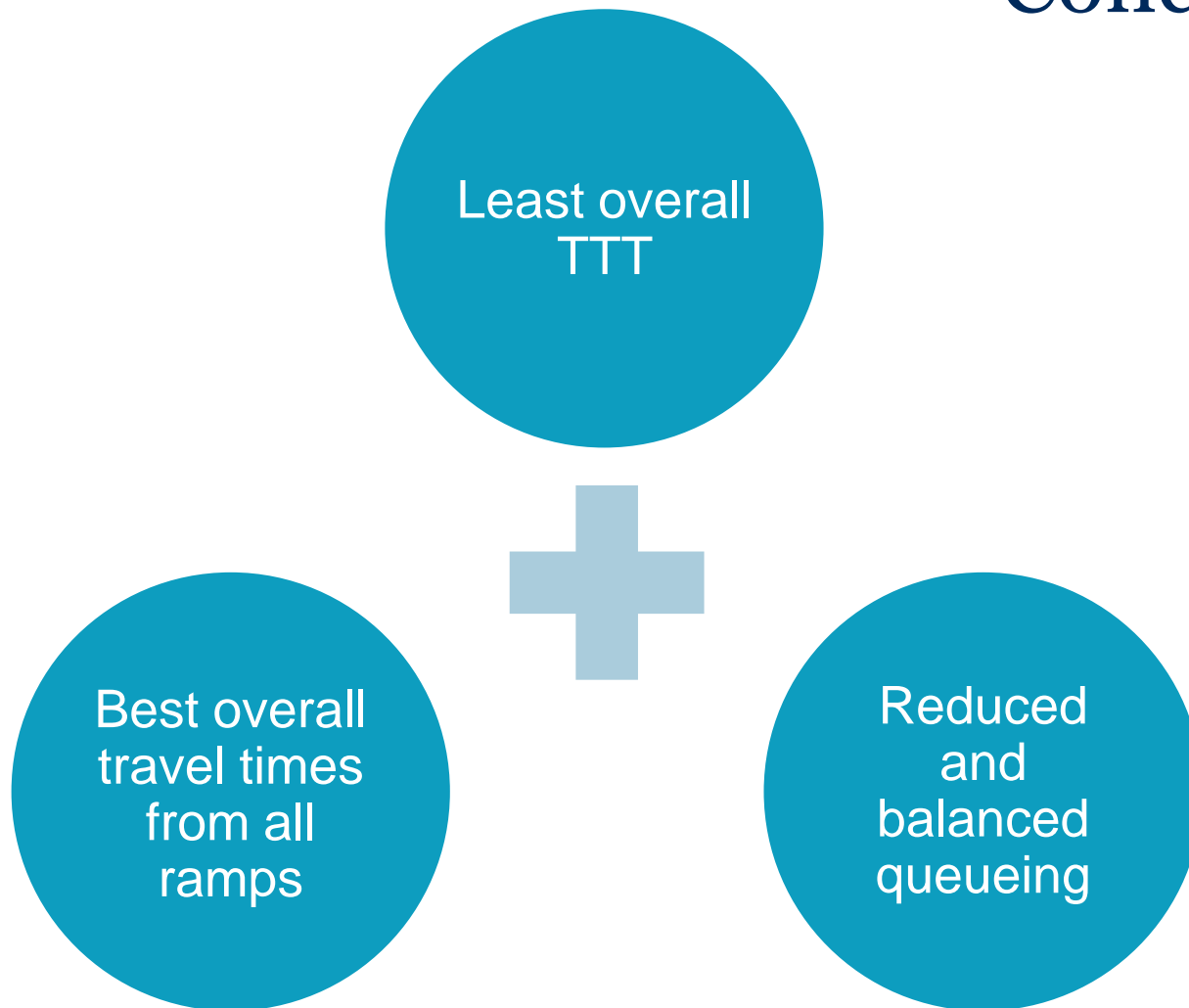

# Status

...

*R & D*  
*Looking for Partner*

Research and Lab  
Testing



Thank You!

Kasra Rezaee

[kasra.rezaee@mail.utoronto.ca](mailto:kasra.rezaee@mail.utoronto.ca)

Baher Abdulhai

[baher.abdulhai@utoronto.ca](mailto:baher.abdulhai@utoronto.ca)

